

Scissor Lift Cart  
 Capacity » 800 Pounds  
 Deck » 25.50" X 30.50" Roller Conveyor  
 Deck » 38.75" X 30.75" & 6.75" X 30.75"  
 Lowered Height » 9.25" Top of Rollers Below Deck  
 Raised Height » 12" Top of Rollers Above Deck  
 Travel » 21.25"  
 Base » 72" X 30.75" With Ø3.5" Flanged Casters X4  
 Power » 120 VAC / 1PH/ 60 Hz Hydraulic, TEFC  
 Power Unit Base Mount W/ Cover  
 Control » 2 Hand Push Button – Lift/Lower  
 Paint » Lange Lift Shadow Gray

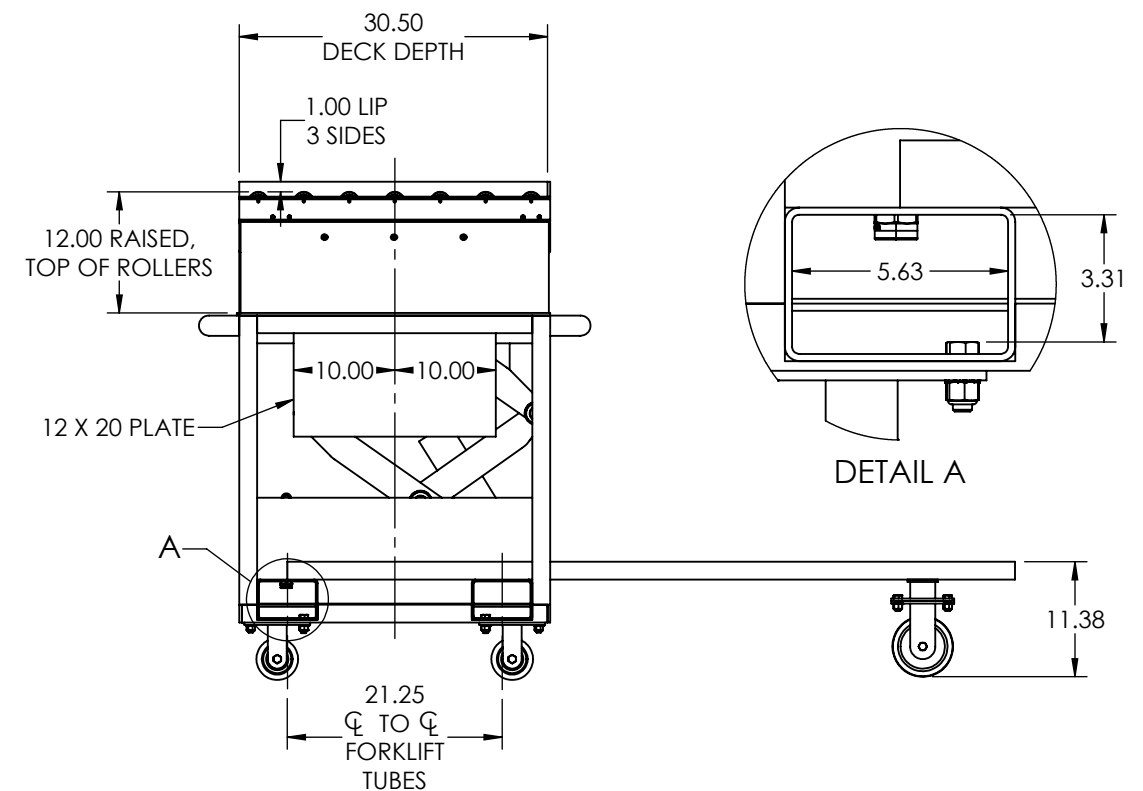
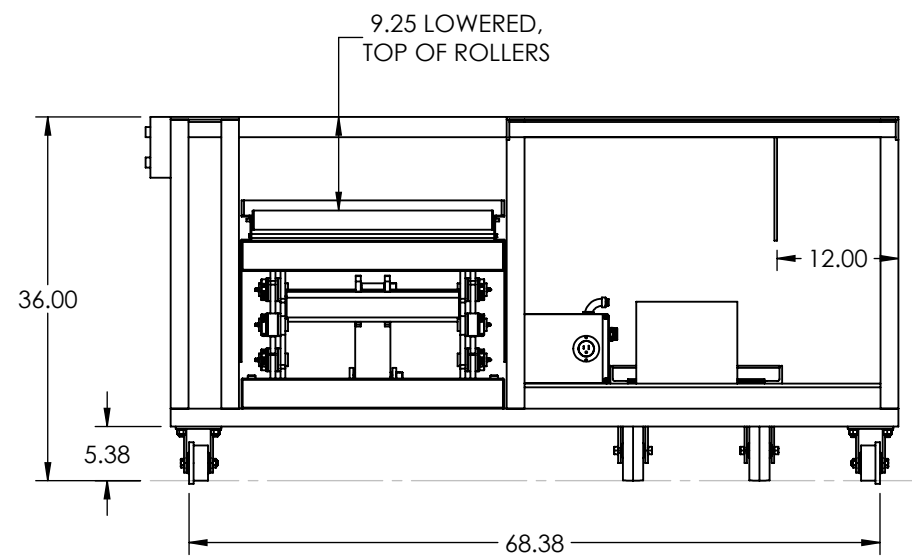
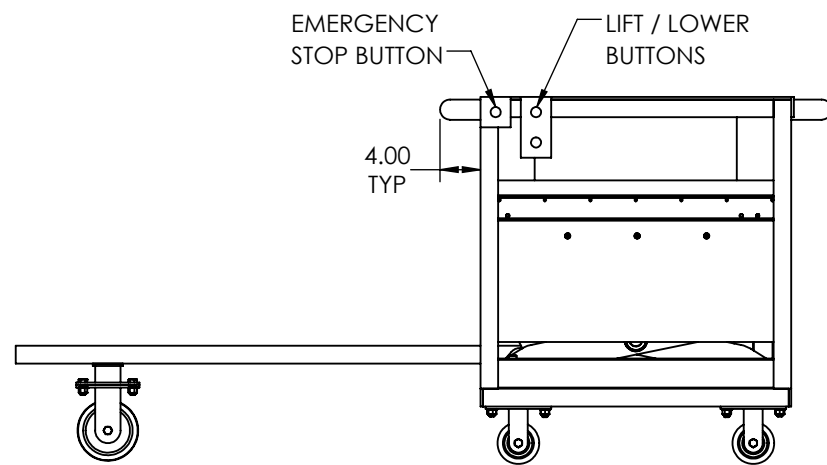
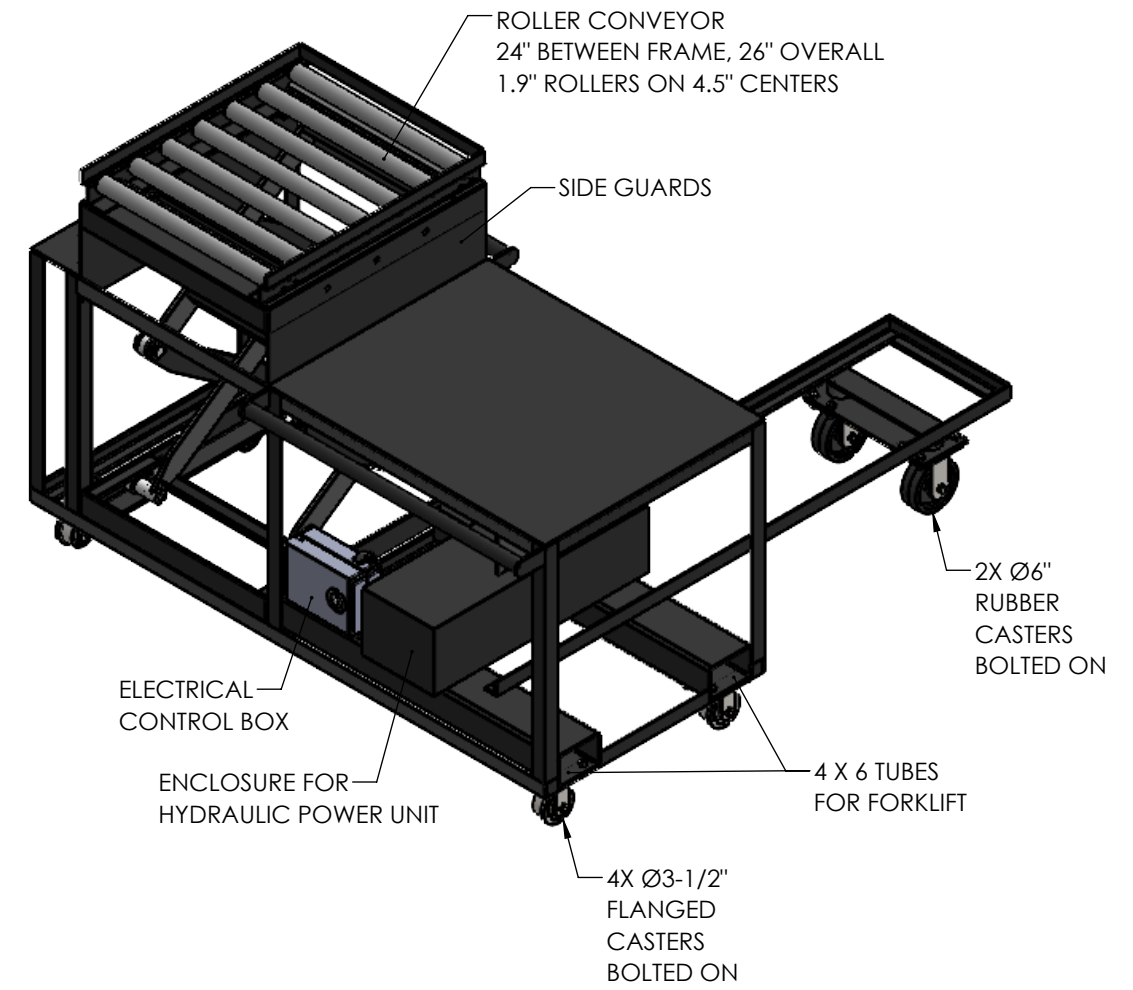
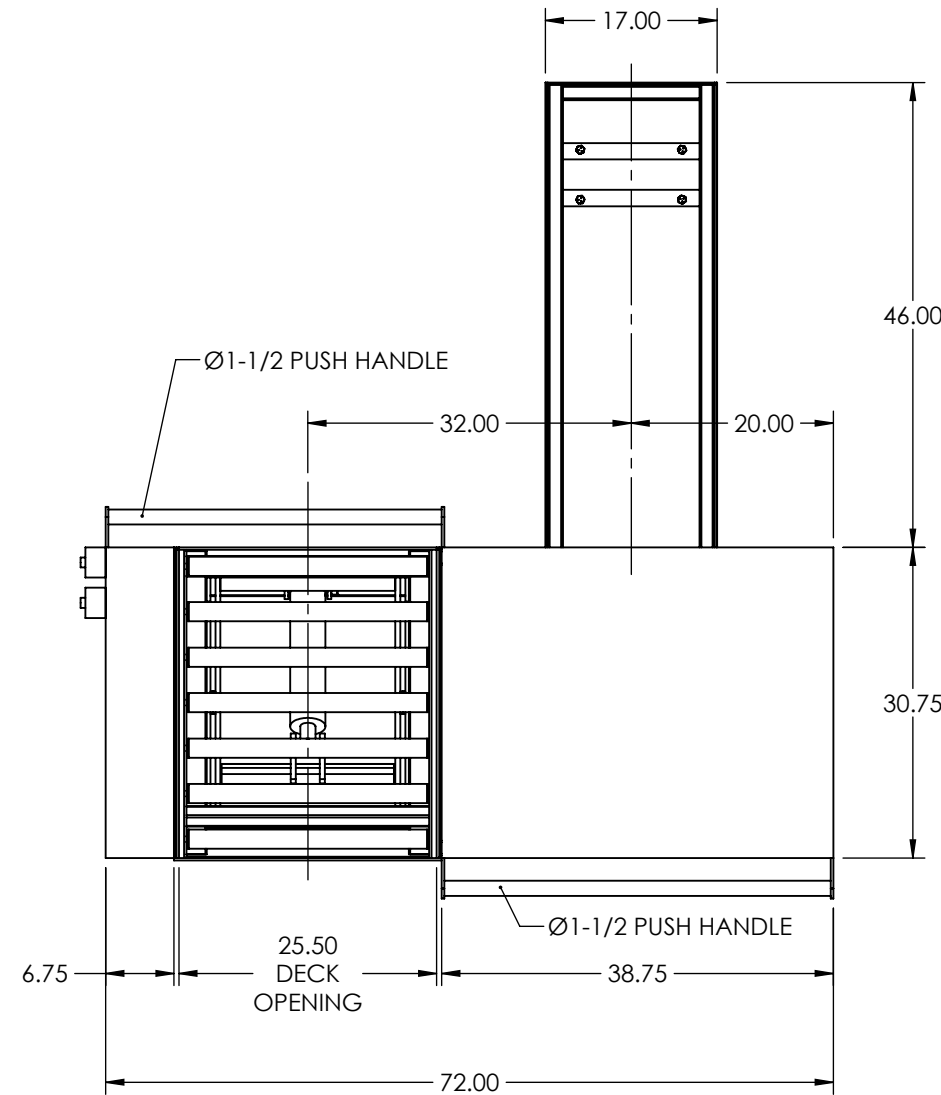
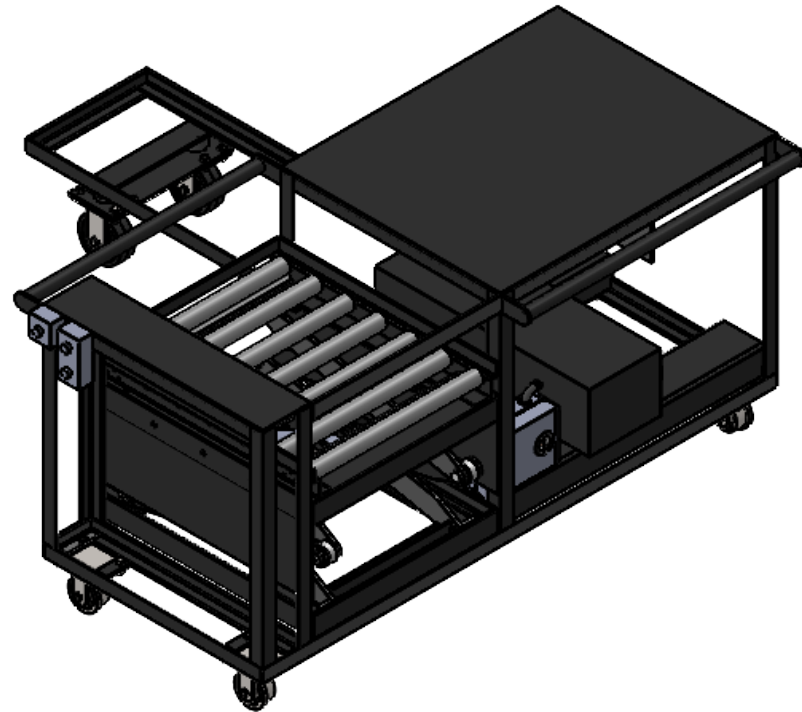

RETURN SIGNED APPROVAL DRAWING TO LANGE LIFT BY E-MAIL OR FAX. LEAD TIMES ARE DRIVEN BY THE RECEIPT OF THE SIGNED APPROVAL DRAWING FOR ALL CUSTOM AND MODIFIED PRODUCTS.

**APPROVED FOR PRODUCTION**

PRINT NAME: \_\_\_\_\_ DATE: \_\_\_\_\_

APPROVAL SIGNATURE: \_\_\_\_\_

PROPRIETARY AND CONFIDENTIAL, THE INFORMATION CONTAINED IN THIS DRAWING IS THE SOLE PROPERTY OF LANGE LIFT. ANY REPRODUCTION IN PART OR AS A WHOLE WITHOUT THE WRITTEN PERMISSION OF LANGE LIFT IS PROHIBITED.



BREAK SHARP EDGES THIRD ANGLE PROJECTION	TOLERANCES UNLESS NOTED X.XX +/- 0.10 X.XXX +/- 0.030 ANGLE +/- 0.5° DIMENSIONS ARE IN INCHES	DESCRIPTION: <b>SCISSOR LIFT CART</b>	REV: <b>C</b>
SCALE: NTS	DRAWN BY: DBK	DATE: 1/12/2022	DWG NO: D2111306-01
		SHEET: 1 OF 1	