

SPECIFICATIONS:

MODEL: L-1000 SPECIAL
 CAPACITY: 1000#
 DECK: 36"Ø
 BASE: 28" SQUARE
 RAISED HT.: 36"
 LOWERED HT.: 18"
 TRAVEL: 18"
 POWER: AIR/HYDRAULIC
 CONTROLS: FOOT PEDALS

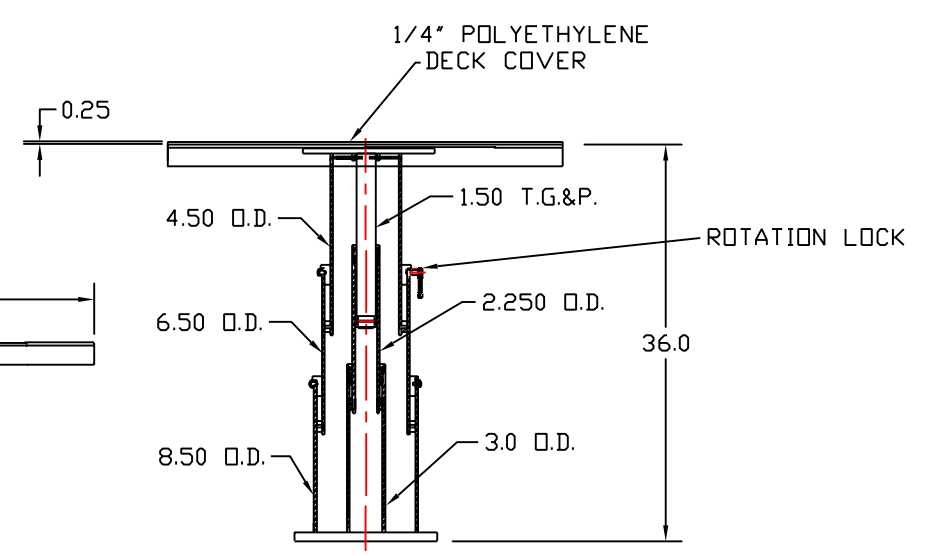
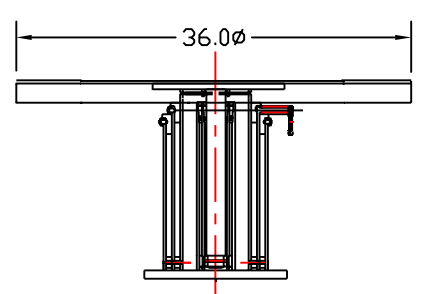
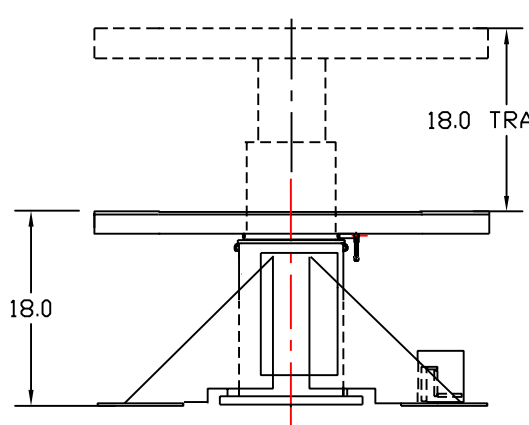

SECTION A-A

L-1000 SPECIAL LIFTS

SERIAL NUMBER 17692, 17693, 21468

	Menomonee Falls Wisconsin U.S.A. 800-558-0577	
	DRAWN BY: J.P. WARREN	
	CHECKED BY:	DATE:
	SCALE: 1/8	PART NO.:
TITLE: SPECIAL L-1000 PNEUMATIC POWERED		
REV.	DATE	DWG. NO.: S/N 21468