

TIPSTER 4K

SN #17741

MODEL: TIPSTER 4K

CAPACITY: 4000#

BIN SIZE: 60" WIDE x 63" HT. x 66" DEEP TIP ANGLE 120 DEG.

POWER: 5 H.P. 230 VAC/3 PH./60 HZ.

-MOTOR COUPLED TO A HIGH PRESSURE GEAR TYPE HYDRAULIC PUMP, PRESSURE RELIEF VALVE, CHECK VALVE, ADJUSTABLE PRESSURE COMPENSATED FLOW CONTROL SOLENOID ACTUATED 4-WAY VALVE, DUAL DBL. ACTING HYDRAULIC LIFT CYLINDERS, REMOTE LOCATION WITH 6 FT. HOSES & CONDUIT.

CONTROLS: UP AND DOWN TRAVEL LIMIT SWITCHES WIRED TO A TERMINAL STRIP INSIDE A NEMA 12 ENCLOSURE.

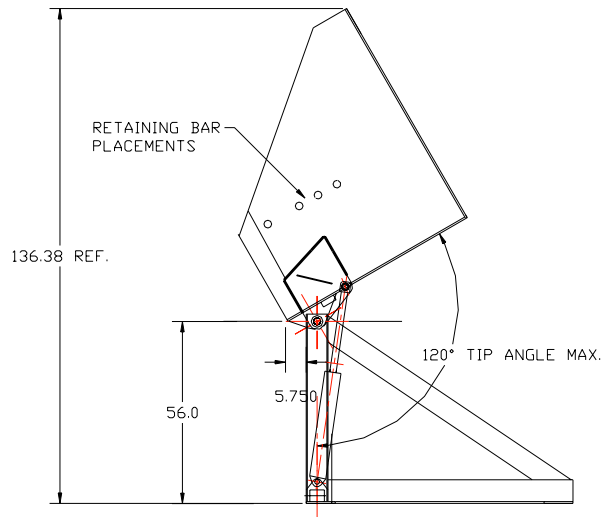

TIPSTER IN DUMP POSITION

